

Surname	Centre Number	Candidate Number
First name(s)		0



GCSE

3300U10-1



A24-3300U10-1

MONDAY, 11 NOVEMBER 2024 – MORNING

MATHEMATICS
UNIT 1: NON-CALCULATOR
FOUNDATION TIER

1 hour 30 minutes

ADDITIONAL MATERIALS

The use of a calculator is not permitted in this examination.
A ruler, protractor and a pair of compasses may be required.

INSTRUCTIONS TO CANDIDATES

Use black ink or black ball-point pen. Do not use gel pen or correction fluid.

You may use a pencil for graphs and diagrams only.

Write your name, centre number and candidate number in the spaces at the top of this page.

Answer **all** questions.

Write your answers in the spaces provided in this booklet.
If you run out of space, use the additional page(s) at the back of the booklet, taking care to number the question(s) correctly.

Take π as 3.14.

INFORMATION FOR CANDIDATES

You should give details of your method of solution when appropriate.

Unless stated, diagrams are not drawn to scale.

Scale drawing solutions will not be acceptable where you are asked to calculate.

The number of marks is given in brackets at the end of each question or part-question.

In question **6**, the assessment will take into account the quality of your linguistic and mathematical organisation, communication and accuracy in writing.

For Examiner's use only		
Question	Maximum Mark	Mark Awarded
1.	2	
2.	3	
3.	2	
4.	3	
5.	4	
6.	5	
7.	5	
8.	3	
9.	3	
10.	2	
11.	5	
12.	2	
13.	5	
14.	4	
15.	4	
16.	6	
17.	4	
18.	3	
Total	65	



NOV243300U10101

Formula List – Foundation Tier

Area of trapezium $= \frac{1}{2} (a + b)h$

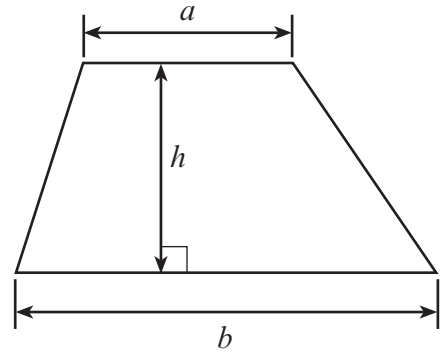

1. (a) Put a cross (X) at the midpoint of AB .

[1]

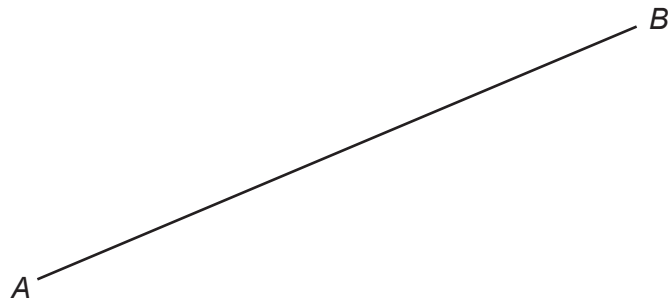

- (b) Draw a line through the point K that is perpendicular to MN .

[1]

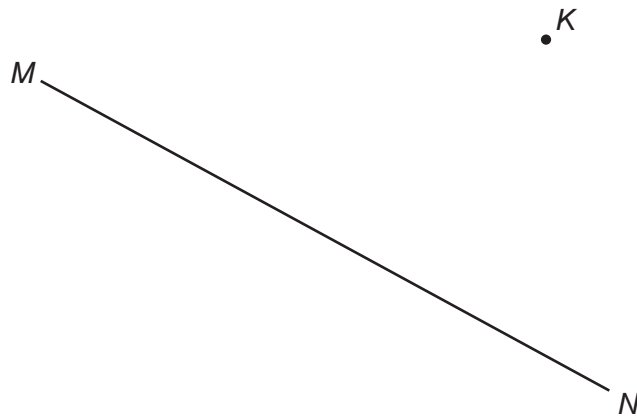

2. (a) Write down the value of the 3 in the number 532 719. [1]

.....

- (b) Add the numbers 865 and 92 and 407. [1]

.....

.....

.....

.....

- (c) Subtract 647 from 1029. [1]

.....

.....

.....

3. (a) Which is the best metric unit for measuring the mass of a pencil?
Circle the correct answer. [1]

kilograms grams tonnes centimetres milligrams

- (b) Which is the best metric unit for measuring the distance from Swansea to Wrexham?
Circle the correct answer. [1]

millimetres metres kilometres litres kilograms



4. (a) Draw $\hat{DEF} = 57^\circ$.
The line EF has been drawn for you. [1]



- (b) Dafydd draws an acute angle.
The angle is the same size as half a right angle.
What is the size of the acute angle? [2]

.....

The size of the acute angle is°

5. (a) Write 25 378 correct to the nearest 100. [1]

.....

- (b) Write down the next number in this sequence. [1]

13, 25, 37, 49,

.....

- (c) Divide 10 kg by 4.
Give your answer in grams. [2]

.....

.....

.....

Answer is g

3300U101
05



6. *In this question, you will be assessed on the quality of your organisation, communication and accuracy in writing.*

Shape A is a regular hexagon.
The length of each side is 5 cm.

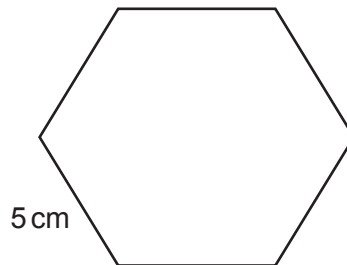

Shape B is a square.
The length of each side is 7.5 cm.

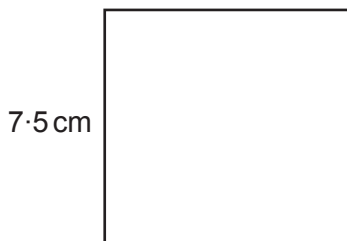

Diagrams not drawn to scale

Show that the perimeter of Shape A is equal to the perimeter of Shape B.
You must show all your working.

[3 + 2 OCW]

.....

.....

.....

.....

.....

.....

.....

.....



7. Mrs Lewis asked each student in Year 11 what kind of music they preferred. She gave the students three options: Hip Hop, Pop and Rock. The pie chart below shows the results.

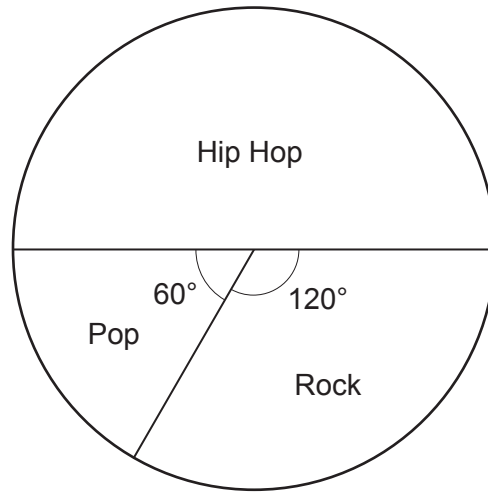

- (a) Mrs Lewis chooses one of the students at random. What is the probability that this student chose Hip Hop? [1]

.....

.....

- (b) 45 students chose Hip Hop. How many students are there in total? [2]

.....

.....

- (c) What fraction of these students chose Pop? [2]

.....

.....



8. (a) Solve $7x = 63$. [1]

.....

.....

- (b) Solve $27 - x = 19$. [1]

.....

.....

- (c) Simplify $17k - 8k + 5k$. [1]

.....

.....

9. (a) Write these numbers in order in the boxes below.
Start with the smallest number. [1]

3 -17 12 -6

Smallest \longrightarrow Largest

- (b) A number line is shown below.
Which number is the arrow pointing to? [1]

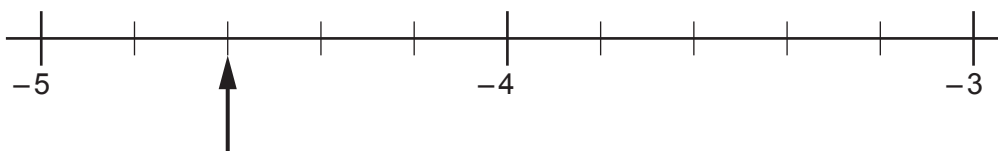

The number is



(c) Calculate $-13 + (-19)$.

[1]

.....

.....

.....

10. Jan has 7 carrots and 3 potatoes in a box.
She chooses one vegetable at random from the box.

On the probability scale below, mark the points C and P, where:

- C is the probability of Jan choosing a carrot
- P is the probability of Jan choosing a potato.

[2]

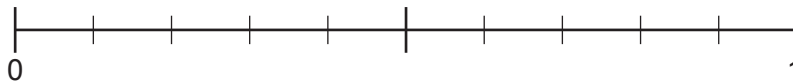

.....

.....

.....



11. A number machine is shown below.

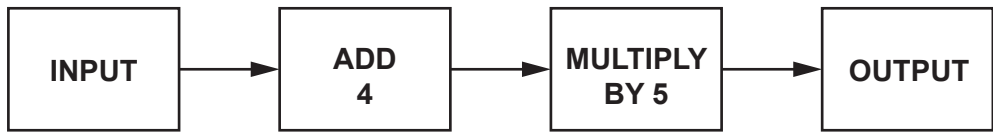

Complete the table below.

[5]

INPUT	OUTPUT
-7	
	-100
2.5	
<i>n</i>	

Space for working:

.....

.....

.....

.....

.....

.....

.....

.....

.....

.....

12. **Estimate** the value of 33×7940 .
You must show your approximations in your working.

[2]

.....

.....

.....

.....



13. Bethan has two brothers, Andrew and Richard.

Andrew is 7 years older than Bethan.
Richard is 3 years older than Andrew.

(a) Today, the sum of all their ages is 59 years.
How old are Bethan, Andrew and Richard today? [2]

.....
.....
.....
.....
.....
.....
.....
.....

Bethan = years old
Andrew = years old
Richard = years old

(b) (i) Write down the ratio of Andrew's age to Richard's age when Andrew is 27.
Write the ratio in its simplest form. [2]

.....
.....
.....

Ratio of Andrew's age to Richard's age = :

(ii) Explain why the ratio of Andrew's age to Richard's age can never be 1 : 1. [1]

.....
.....
.....



14. The diagram below shows the cross-section of a solid.

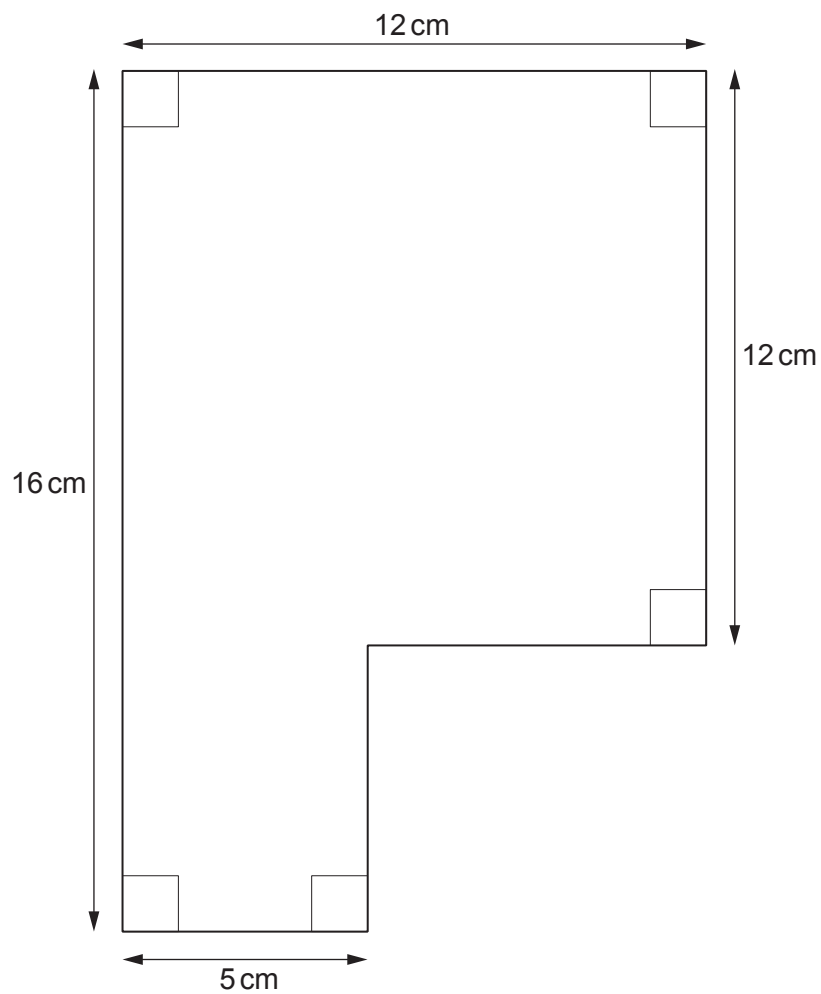

The solid has a height of 2 cm.

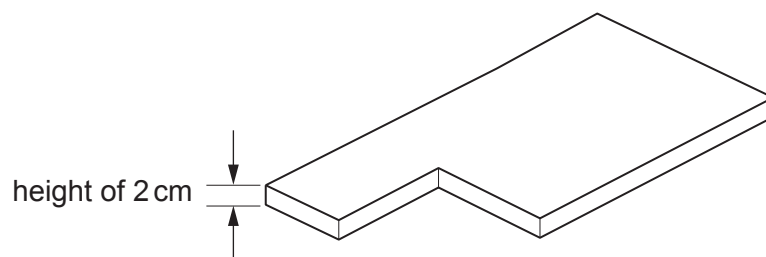

Diagrams not drawn to scale



15. Three of the four vertices of a parallelogram have the following coordinates.

(4, 3) (5, -1) (8, 3)

Plot these points on the coordinate grid below.

Then, plot **all three** possible points for the fourth vertex.
Write down the coordinates of these three points.

[4]

.....

.....

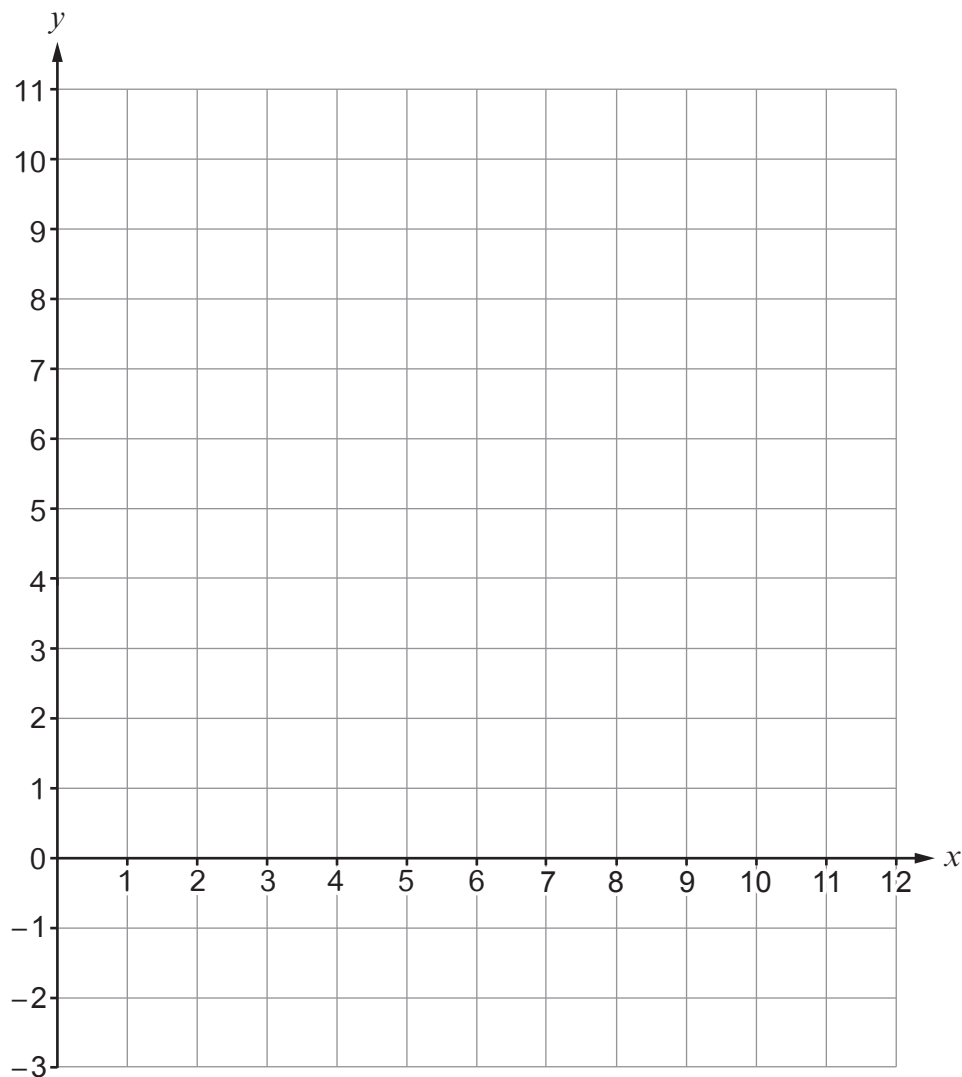

The **three** possible points for the fourth vertex are

(..... ,) (..... ,) (..... ,)



Examiner only

16. Each of the 3 diagrams below represents a balance. For each balance, the total mass on the left-hand side is equal to the total mass on the right-hand side.

Find the values of **A**, **B** and **C**.

[6]

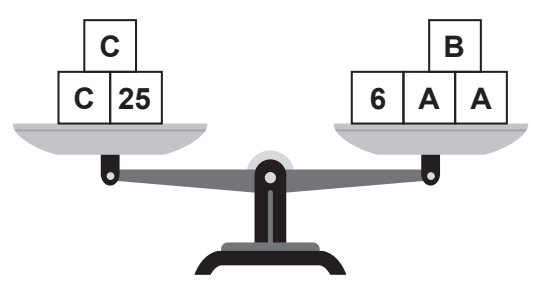
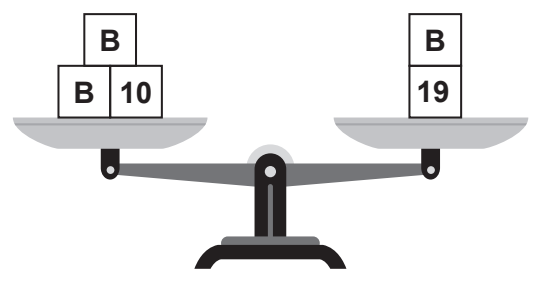
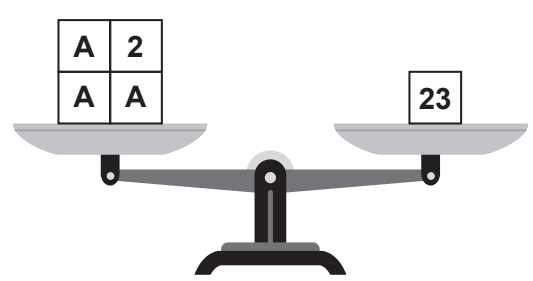

.....

.....

.....

.....

.....

.....

.....

.....

.....

.....

A = **B** = **C** =



17. The shape below has rotational symmetry of order 6.

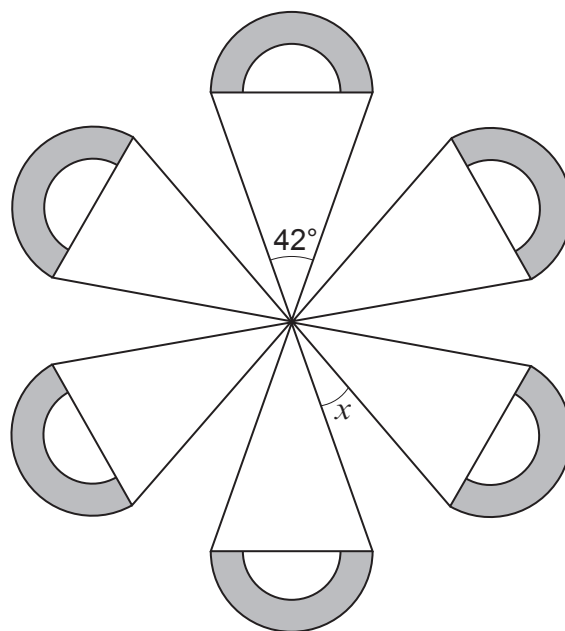

Diagram not drawn to scale

Find the size of angle x .
You must show all your working.

[4]

.....

.....

.....

.....

.....

.....

.....

.....

.....

.....

.....

.....

.....

.....

.....

.....

.....

.....

.....

.....

.....

.....



18. Calculate the area of the trapezium shown below.
You must give the units of your answer.

[3]

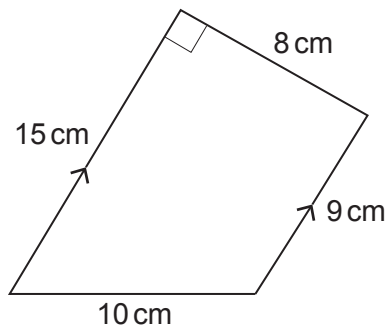

Diagram not drawn to scale

.....

.....

.....

.....

.....

.....

END OF PAPER



BLANK PAGE

**PLEASE DO NOT WRITE
ON THIS PAGE**



BLANK PAGE

**PLEASE DO NOT WRITE
ON THIS PAGE**

